

SCHOTTKY BARRIER RECTIFIERS

REVERSE VOLTAGE - 30 to 40 Volts
FORWARD CURRENT - 30 Amperes

FEATURES

- Metal of silicon rectifier, majority carrier conductor
- Guard ring for transient protection
- Low power loss, high efficiency
- High current capability, low VF
- High surge capacity
- Plastic package has UL flammability classification 94V-0
- For use in low voltage, high frequency inverters, free whelling, and polarity protection applications

MECHANICAL DATA

- Case : D²PAK molded plastic
- Polarity : As marked on the body
- Weight : 0.06 ounces, 1.7 grams

D²PAK

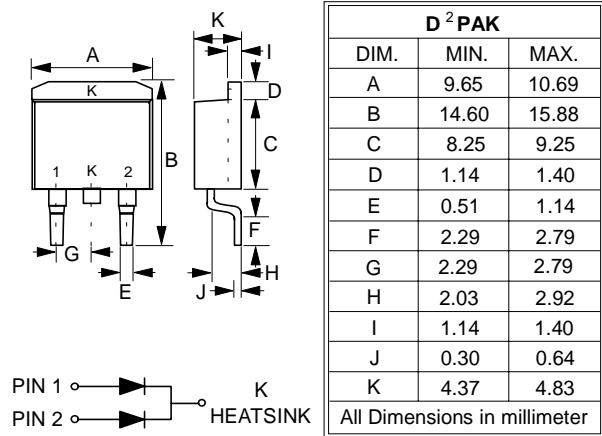

MAXIMUM RATINGS AND ELECTRICAL CHARACTERISTICS

Ratings at 25°C ambient temperature unless otherwise specified.
Single phase, half wave, 60Hz, resistive or inductive load.
For capacitive load, derate current by 20%

CHARACTERISTICS	SYMBOL	SBG3030CT	SBG3040CT	UNIT
Maximum Recurrent Peak Reverse Voltage	V _{RRM}	30	40	V
Maximum RMS Voltage	V _{RMS}	21	28	V
Maximum DC Blocking Voltage	V _{DC}	30	40	V
Maximum Average Forward Rectified Current @T _C =100°C	I _(AV)	30		A
Peak Forward Surge Current 8.3ms single half sine-wave superimposed on rated load (JEDEC METHOD)	I _{FSM}	250		A
Maximum Forward Voltage at 15A DC (Note 1)	V _F	0.55		V
Maximum DC Reverse Current at Rated DC Blocking Voltage @T _J =25°C @T _J =100°C	I _R	1.0 75		mA
Typical Junction Capacitance per element (Note 2)	C _J	420		pF
Typical Thermal Resistance (Note 3)	R _{θJC}	1.5		°C/W
Operating Temperature Range	T _J	-55 to +125		°C
Storage Temperature Range	T _{STG}	-55 to +150		°C

NOTES : 1. 300us Pulse Width, 2% Duty Cycle.
2. Measured at 1.0MHz and applied reverse voltage of 4.0V DC.
3. Thermal Resistance Junction to Case.

